

Please make sure that you print this resource at 100% so that all measurements are correct.

To do this, follow the relevant steps below.

Adobe Reader or Adobe Acrobat

- Adobe Reader is a free PDF viewer, from Adobe. To install a copy of Adobe Reader, go to <https://get.adobe.com/uk/reader/>.
- Once Adobe Reader is installed, open your PDF.
- Go to File>Print.
- Under 'Page Sizing & Handling', select 'Size'.
- From here, make sure that 'Actual Size' is selected.
- Print this page as a test, making sure that the shape below is the correct size once printed.
- If the test print is correct, print your PDF.

Foxit Reader

- Go to File>Print.
- Set the 'Scaling' to 'None'.
- Print this page as a test, making sure that the shape below is the correct size once printed.
- If the test print is correct, print your PDF.

Web Browser

- If printing from a web browser, such as Chrome, Firefox or Microsoft Edge make sure that your printer is set to print at 100%, either by unticking 'Fit to Page' or selecting 'Actual Size'.
- Print this page as a test, making sure that the shape below is the correct size once printed.
- If the test print is correct, print your PDF.

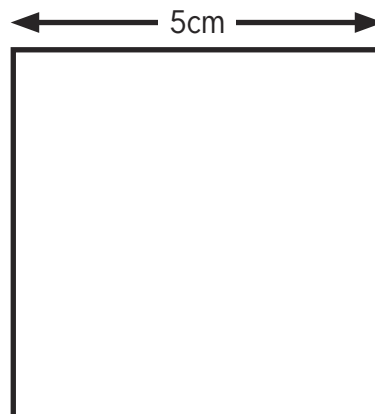

Maths Revision



Number and Place Value

Count forwards and backwards in 4, 8, 50 and 100.

1. Continue the sequences:

a. 4, 8, 12, 16, _____, _____, _____

b. 24, 32, 40, _____, _____, _____

c. 900, 800, 700, _____, _____, _____

d. 150, 200, 250, _____, _____, _____

Find 10 or 100 more or less than a given number.

2. What number is 10 more than 73?

3. What number is 100 less than 340?

Recognise the place value of each digit in a three-digit number.

4. Underline the tens digit in the following numbers:

562

584

703

821

Compare and order numbers up to 1000.

5. Write a number so that each sentence makes sense:

a. $345 < \underline{\hspace{2cm}}$

b. $294 > \underline{\hspace{2cm}}$

c. $833 = \underline{\hspace{2cm}}$

6. Order the following numbers from largest to smallest:

77

86

78

84

74

Largest _____ Smallest

7. Order these numbers from smallest to largest:

289

298

258

247

293

Smallest _____ Largest

Identify, represent and estimate numbers using different representations.

8. What number is shown:

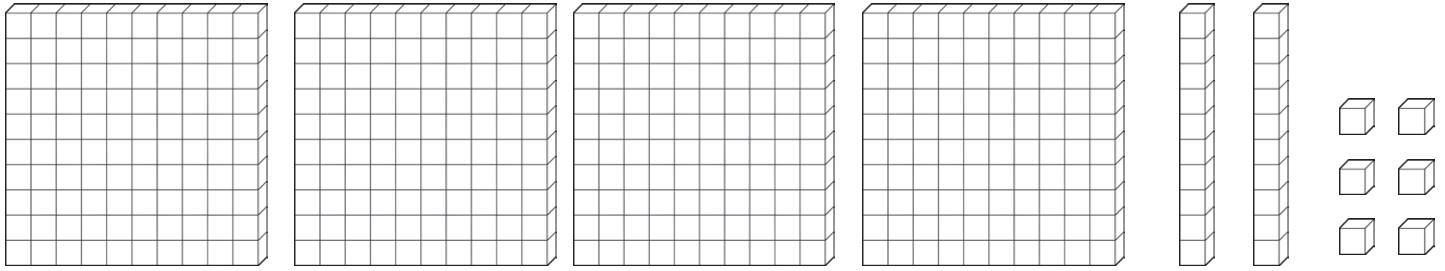

Read and write numbers up to 1000 in numerals and in words.

9. Write 357 in words.

10. Write two hundred and seventy-four in numerals.

Solve number problems and practical problems.

11. What needs to be added to the following number to make 234?

$$204 + \underline{\hspace{2cm}}$$

12. Cross out the Dienes that are not needed to represent the number 162.

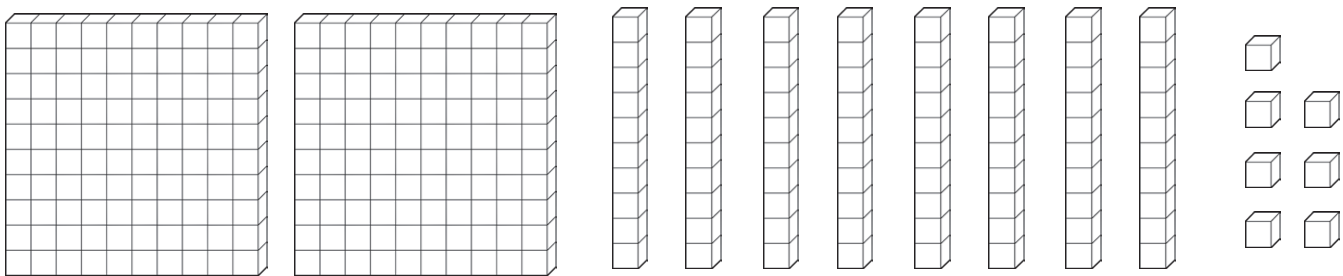

Addition and Subtraction

Add and subtract numbers mentally.

13. Calculate the following:

a. $286 + 4 = \underline{\hspace{2cm}}$

b. $256 - 30 = \underline{\hspace{2cm}}$

c. $172 + 300 = \underline{\hspace{2cm}}$

Add and subtract numbers with up to three digits using formal written methods.

14. Calculate the following:

a.

		6	7	8
+		3	2	3

b.

	6	8	3
-	2	5	1

c.

	3	6	4
-	1	2	9

Estimate the answer to a calculation and use the inverse operation to check.

15. Use the inverse to check the following calculations. Circle 'Correct' or 'Incorrect':

a. $328 + 126 = 456$ _____ Correct/Incorrect

b. $267 - 138 = 129$ _____ Correct/Incorrect

Solve problems including missing numbers.

16. Fill in the missing numbers to make these calculations correct:

a.

4	7	2	+	3	6		=		3	6
---	---	---	---	---	---	--	---	--	---	---

b. There are 460 people on a plane. 125 of the passengers are British, 104 are American and the rest are French. How many French people are on board the plane?

Multiplication and Division

Recall and use multiplication and division facts for the 3, 4 and 8 times tables.

17. Use your knowledge of the 3, 4 and 8 times tables to complete these calculations:

a. _____ \times 4 = 32

c. $8 \times 6 =$ _____

e. _____ \div 12 = 4

b. $3 \times$ _____ = 27

d. $33 \div$ _____ = 3

f. $40 \div$ _____ = 8

Use known facts to solve multiplication and division problems including two-digit multiplied by one-digit numbers.

18. Partition these numbers or use a column method to calculate these:

a. $24 \times 3 =$ _____ c. $56 \div 4 =$ _____

b. $18 \times 4 =$ _____ d. $48 \div 3 =$ _____

Solve problems including missing numbers.

19. Find the missing numbers to complete the following calculations:

a.

4	3	×		=		7	2
---	---	---	--	---	--	---	---

b.

6		×	3	=	1		6
---	--	---	---	---	---	--	---

Solve problems including scaling and correspondence problems.

20. Solve the following problems:

a. There are 8 apples in one box. How many apples are there in 6 boxes?

b. Kangaroos have 2 legs and zebras have 4 legs. A zoo keeper counts 22 legs altogether. How many kangaroos and zebras could there be?

c. 18 cupcakes are shared equally between 3 boxes. How many cupcakes are in each box?

Fractions

Count up and down in tenths.

21. Fill in the missing numbers to complete the sequence:

$\frac{2}{10}$ $\frac{3}{10}$ $\frac{4}{10}$ $\frac{\quad}{10}$ $\frac{6}{10}$

22. Shade in the squares to represent the fraction $\frac{7}{10}$.

--	--	--	--	--	--	--	--	--	--

Find fractions of amounts.

23. Circle $\frac{1}{4}$ of the strawberries.

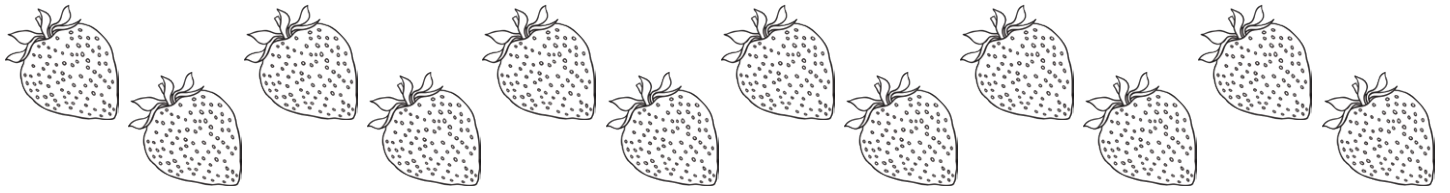

24. Circle $\frac{3}{4}$ of the sweets.



25. What fraction of the apples have been grouped together?

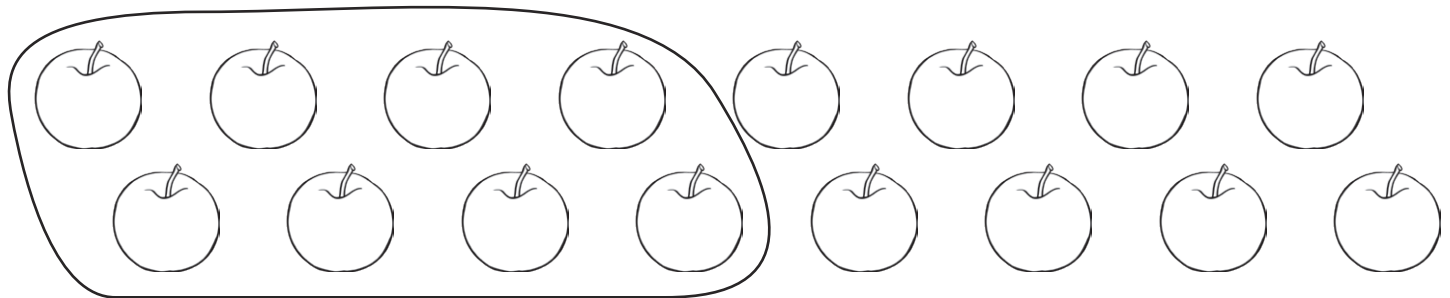

Recognise and show equivalent fractions.

26. Draw lines to match the equivalent fractions.

$\frac{3}{4}$

$\frac{1}{2}$

$\frac{1}{3}$

$\frac{6}{8}$

$\frac{1}{5}$

$\frac{2}{10}$

$\frac{5}{10}$

$\frac{2}{6}$

Add and subtract fractions with the same denominator.

27. Calculate the following:

a. $\frac{2}{5} + \frac{1}{5} =$ _____

b. $\frac{3}{8} + \frac{2}{8} =$ _____

c. $\frac{3}{4} - \frac{1}{4} =$ _____

d. $\frac{7}{8} - \frac{3}{8} =$ _____

Compare and order unit fractions.

28. Order these fractions from smallest to largest:

$\frac{1}{3}$ $\frac{1}{2}$ $\frac{1}{5}$ $\frac{1}{4}$ $\frac{1}{6}$

Smallest _____ Largest

29. Use < or > to complete these number sentences:

a. $\frac{1}{4}$ _____ $\frac{1}{2}$

b. $\frac{7}{8}$ _____ $\frac{3}{8}$

Solve problems involving fractions.

30. A cake is divided into 10 slices. Harry takes 2 slices and Emily takes 3. Write what fraction of the cake is left.

31. Lucy has $\frac{1}{4}$ of £400. Jack has $\frac{3}{4}$ of £200. Who has the most money?

Measurement

Measure, compare, add and subtract measures.

32. Measure this line in cm.



33. How much longer is line A than line B?



34. A block of cheese weighs 250g each. Sam cuts off 120g of cheese. How much is left?

35. Draw a line on jug B so that it shows the same amount of liquid as jug A.

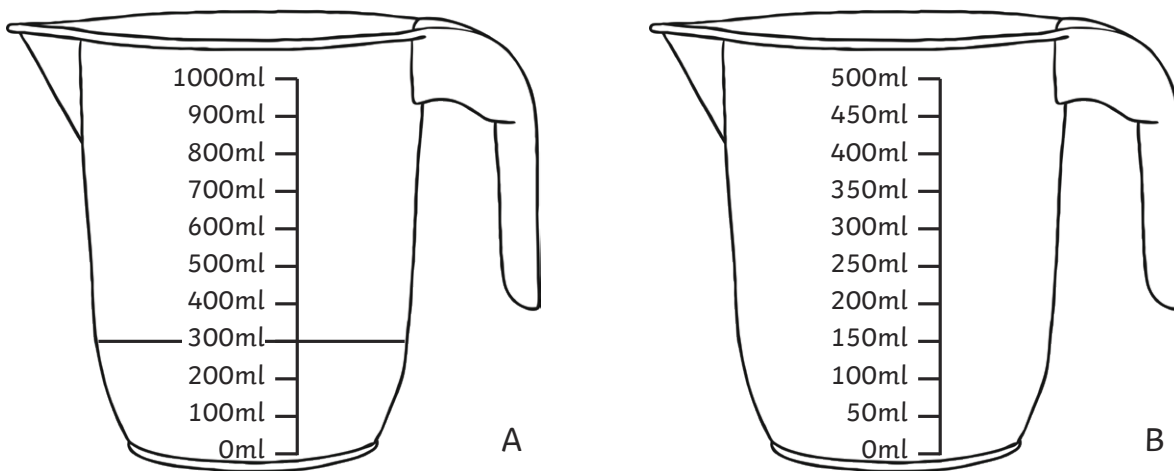

Measure the perimeter of 2D shapes.

36. Calculate the perimeter of the rectangle.

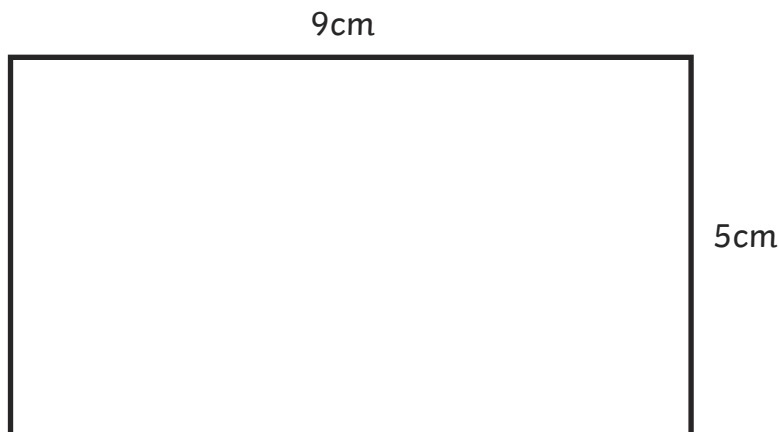

Perimeter = _____

37. A square is 4cm wide. What is its perimeter?

Perimeter = _____

Add and subtract amounts of money, giving change.

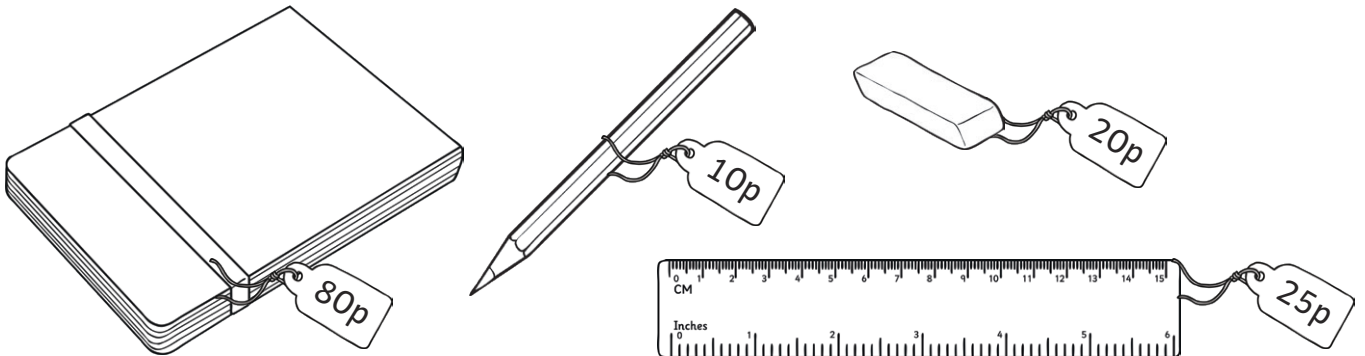

38. Julie buys two rubbers and one pencil. How much change will she get from £1?

39. Zain has a £1 coin. He wants to buy a notebook, a ruler and a pencil. How much more money will he need?

Tell and write the time on an analogue clock and on 12-hour and 24-hour clocks.

40. Write the digital time underneath each clock:

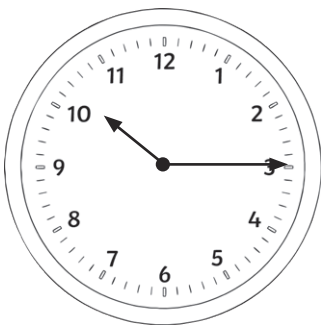

a. _____

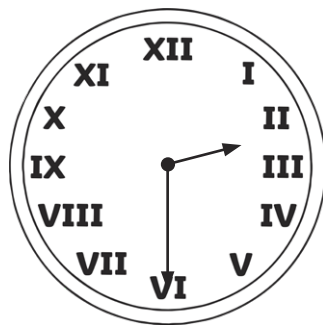

b. _____

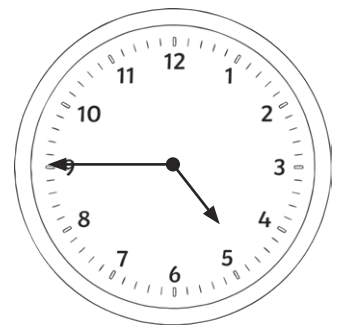

c. _____

41. Match the 12-hour and 24-hour times.

3:45 p.m.	14:00
7:30 a.m.	15:45
12:15 p.m.	08:20
8:20 a.m.	07:30
2:00 p.m.	12:15

Record time in hours, minutes and seconds.

42. A film lasted $2\frac{1}{2}$ hours. How long was the film in minutes?

43. James ran the 400m race in 1 minute and 40 seconds. Haamaad ran it in 85 seconds. Who was the fastest? Explain how you know.

Know the number of seconds in a minute and days in a year.

44. Tania spent 45 days of last year in Spain. How many days was she in the UK?

Geometry

Draw 2D shapes.

45. Draw a square which has sides of 6cm.

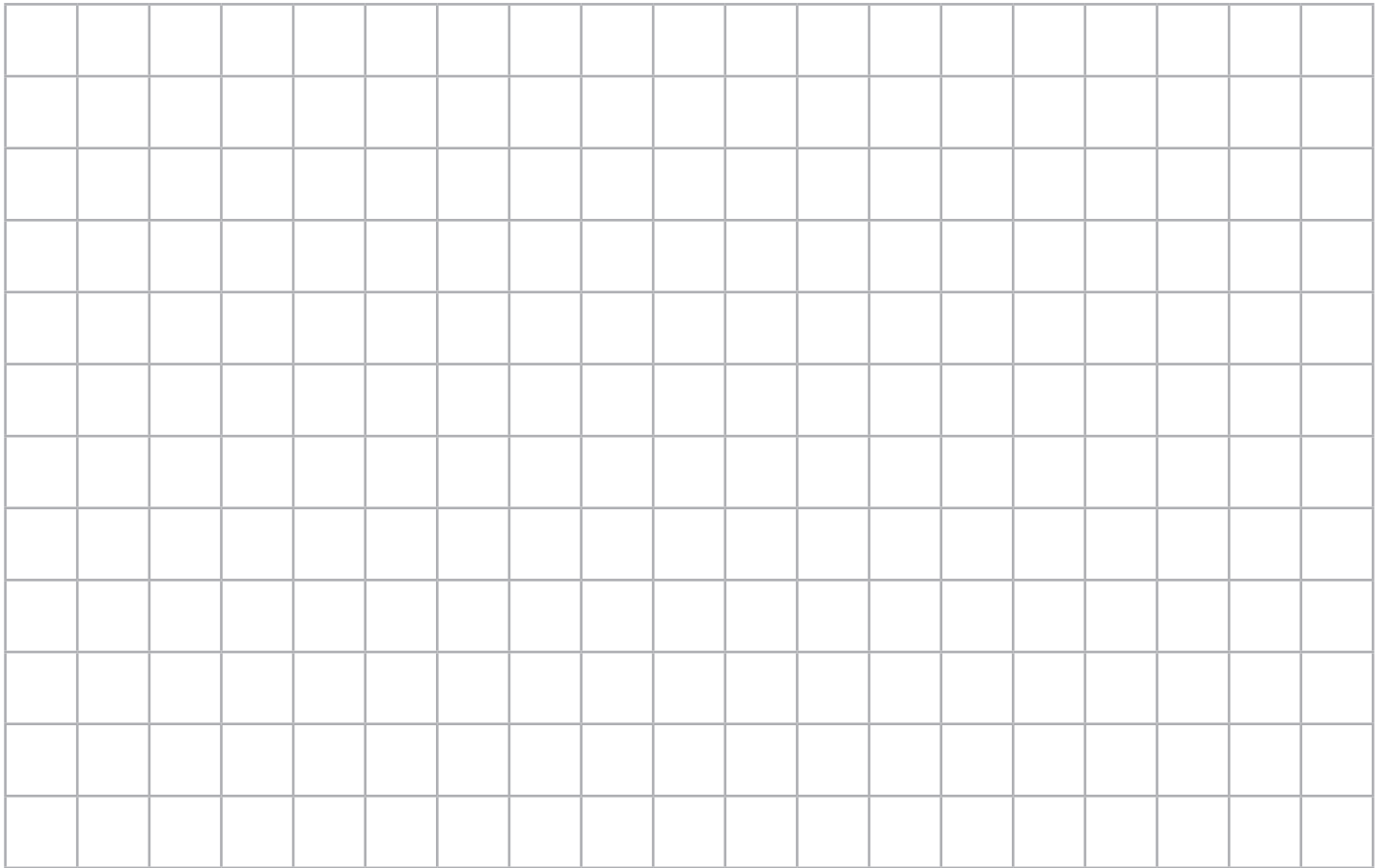

46. Draw a rectangle with a length of 8cm and a width of 2cm.

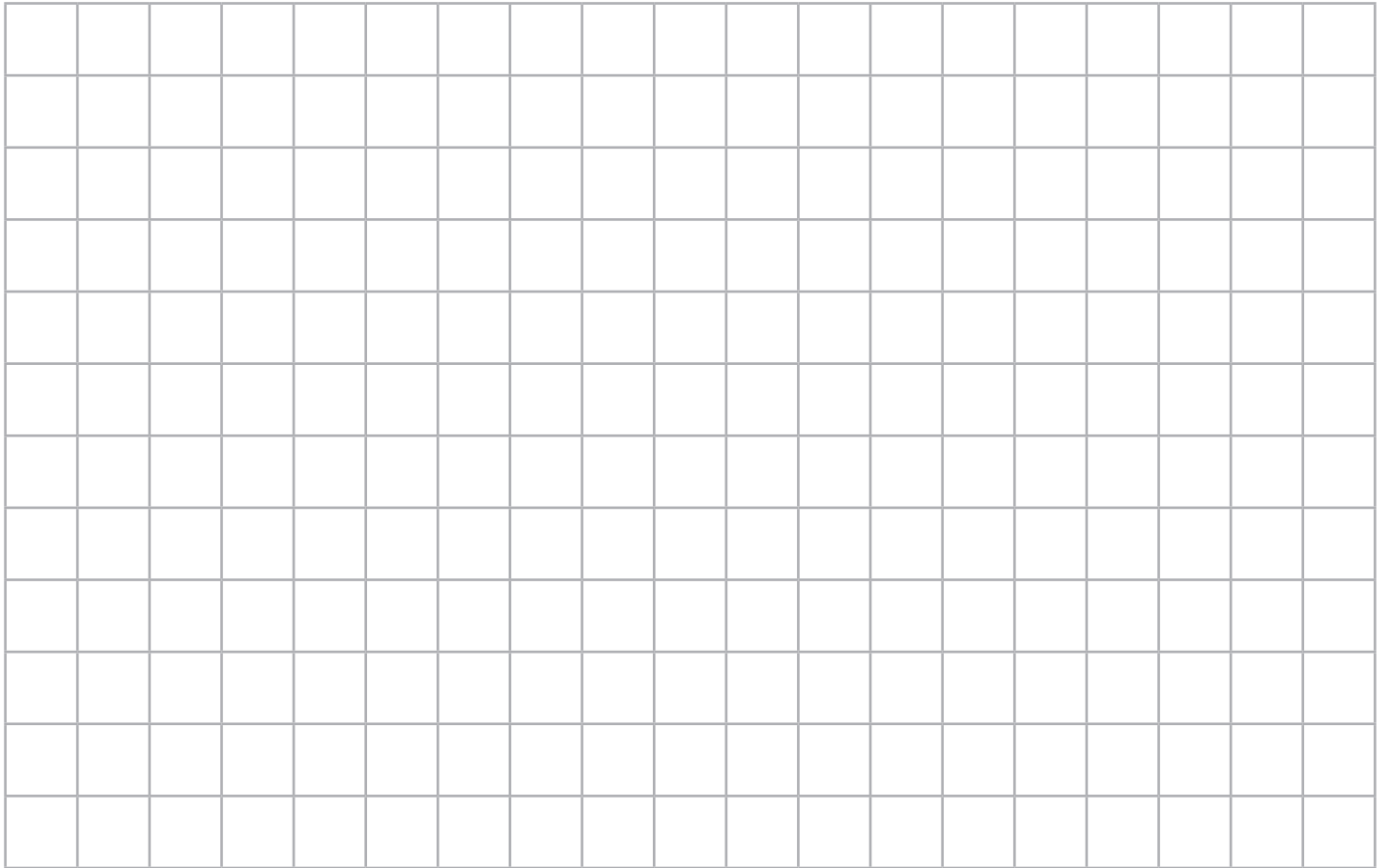

Recognise 3D shapes.

47. Draw lines to match the 3D shapes with their names.

Cuboid

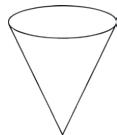

Sphere

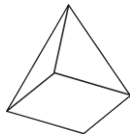

Cone

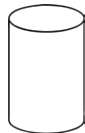

Square-based pyramid

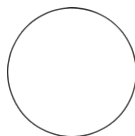

Cylinder

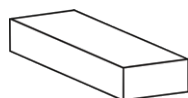

Recognise right angles and related facts.

48. Mark any right angles on this rectangle with a ■.

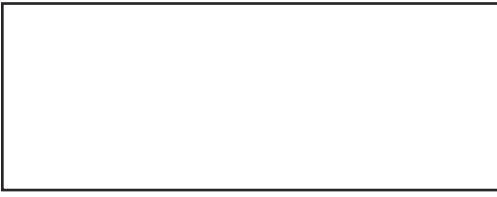

49. Estimate the size of these angles in degrees (°).

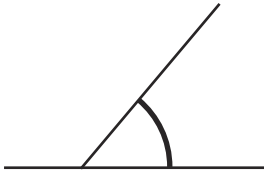

a. _____



b. _____

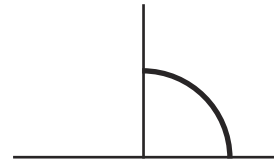

c. _____

Recognise horizontal, vertical, perpendicular and parallel lines.

50. Mark a pair of parallel lines on this shape:



51. Mark a pair of perpendicular lines on this shape:



52. Draw a horizontal line.

53. Draw a vertical line.

Statistics

Interpret and present data in pictograms, bar charts and tables.

54.

Children in Class 3's Favourite Colour

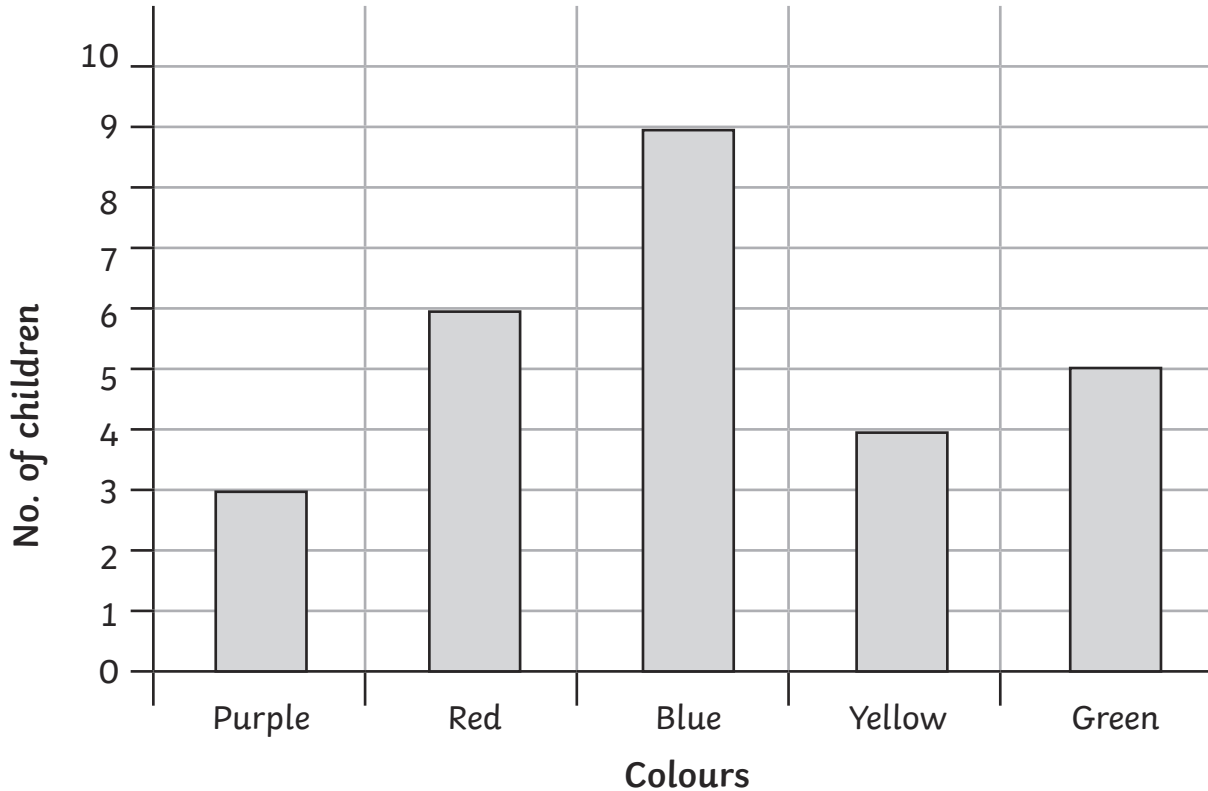

a. How many children chose red as their favourite colour?

b. How many more children chose blue than yellow?

c. How many children were asked to choose their favourite colour?

Solve one and two-step problems using information represented in bar charts, pictograms and tables.

55. This table show how many packets of crisps were sold in a shop over four weeks.

	Week 1	Week 2	Week 3	Week 4
Ready Salted	50	55	48	52
Cheese and Onion	33	38	20	
Salt and Vinegar	15	25	45	30
Chicken	10	12	8	15

a. How many packets of chicken crisps did the shop sell in week 2?

b. Which flavour crisp did the shop sell most of in Week 3?

c. In week 4, the shop sold half the amount of cheese and onion crisps than salt and vinegar. Fill in the table with how many packets of cheese and onion it sold that week.

d. How many more packets of crisps were sold altogether in week 2 than in week 3?
